

# Sylk™ I/O Devices

## SPECIFICATION DATA

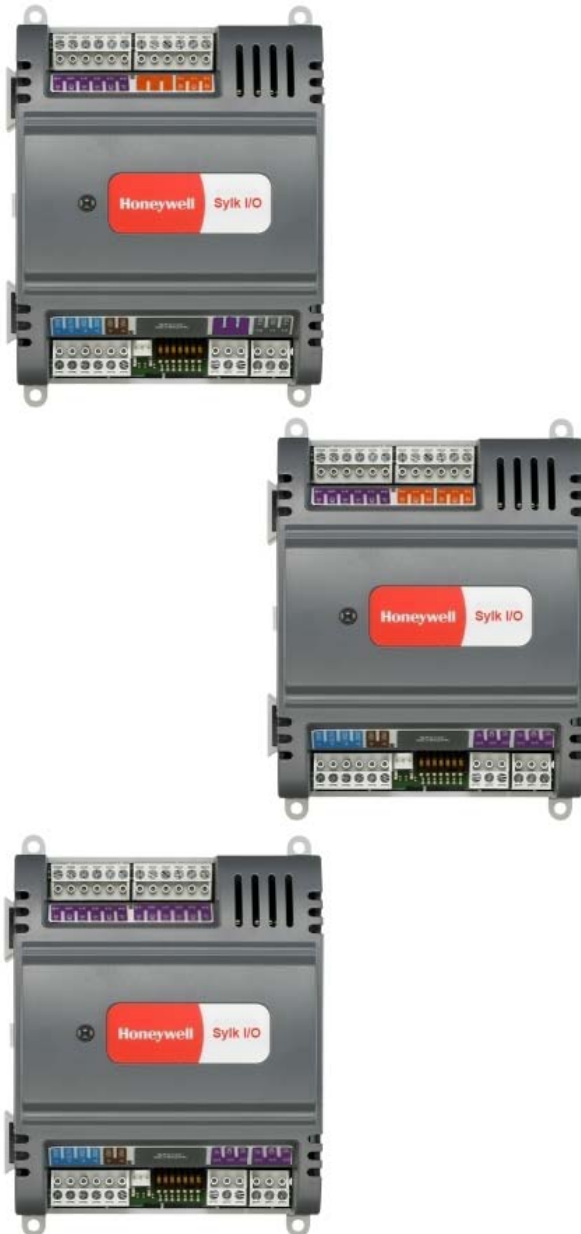

## APPLICATION

The Sylk IO devices are part of the Spyder family. The three IO devices are designed to seamlessly integrate with Spyder with relay controllers using only Sylk™ for communication. These devices expand the footprint of a single Spyder, increasing the controller's ability to be applied in applications that require a large amount of physical I/O. The Sylk IO devices are programmable using existing Spyder wire sheets through the Niagara Framework® software. Since the Sylk IO devices are extensions of the Spyder LON and Spyder BACnet controllers, the same Spyder feature will be leveraged in the WebPro workbench tool and the WEBs-AX JACE controller.

The Sylk IO devices are intended for use in HVAC applications that require a programmable controller where the IO count is more than the full sized Spyder point count. All devices provide flexible, universal inputs for external sensors while SIO6042 and SIO4022 provide a combination of analog and digital outputs.

## FEATURES

- Expands a single Spyder controller's IO count by 8-12 IO per device.
- Up to three devices for Lon Spydres and up to two devices for BACnet Spydres can be applied.
- Communicates through Sylk™ bus freeing up IO for more applications.
- Program logic resides in a single controller and uses the existing Spyder wire sheet.
- Programming is built directly into the Spyder tool.
- Installation can be done locally or remotely.
- Field configurable and programmable for control, input, and output functions using the Niagara Framework® software.
- All wiring connections are made to removable terminal blocks to simplify device installation and replacement.
- The device housing is UL plenum rated.



## DESCRIPTION

The Sylk IO devices are available in three models, as described in Table 1.

**Table 1. Device Configurations.**

Devices	UI (Universal Input)	DI (Digital Input)	AO (Analog Output)	DO (Digital Output)
SI06042	6	0	4	2
SI04022	4	0	2	2
SI012000	12	0	0	0

Each device is programmable because the user chooses which function blocks to use and how to connect them. It is configurable because each function block has user-defined behavior.

## SPECIFICATIONS

### Electrical

**Rated Voltage:** 20-30 Vac; 50/60 Hz

**Power Consumption:**

100 VA for Sylk IO device and all connected loads

**SyLK IO Device only Load:** 3 VA maximum (SI012000), 4 VA maximum (SI04022), 5 VA maximum (SI06042)

### Environmental

**Operating & Storage Temperature Ambient Rating:**  
Minimum -40° F (-40° C); Maximum 150° F (65.5° C)

**Relative Humidity:** 5% to 95% non-condensing

### Dimensions (H/W/D)

See Fig. 1 on page 3 for dimensioned drawings.

**Dimensions:** 6.266 x 4.750 x 2.26 in.  
(159 x 120.6 x 57.4 mm)

### Approval Bodies

UL/cUL (E87741) listed under UL916 (Standard for Open Energy Management Equipment) with plenum rating.

Meets FCC Part 15, Subpart B, Class B (radiated emissions) requirements.

Meets Canadian standard C108.8 (radiated emissions).

Conforms to the following requirements per European Consortium standards:

- EN 61000-6-1; 2001 (EU Immunity).
- EN 61000-6-3; 2001 (EU Emissions).

## Inputs and Outputs

Each device has a combination of digital outputs (DO), analog outputs (AO), and universal input (UI) circuits.

### Digital Triac Output (DO) Circuits

**Voltage Rating:** 20 to 30 Vac @ 50-60Hz

**Current Rating:** 25 mA to 500 mA continuous, 800 mA (AC rms) for 60 milliseconds

### Analog Output (AO) Circuits

Analog outputs are individually configurable for current or voltage.

**ANALOG CURRENT OUTPUTS:**

**Current Output Range:** 4.0 to 20.0 mA

**Output Load Resistance:** 550 Ohms maximum

**ANALOG VOLTAGE OUTPUTS:**

**Voltage Output Range:** 0.0 to 10.0 Vdc

**Maximum Output Current:** 10.0 mA

Analog outputs may be configured as digital outputs and operate as follows:

- False (0%) produces 0 Vdc, (0 mA)
- True (100%) produces the maximum 11 Vdc, (22 mA)

### Universal Input (UI) Circuits

See Table 2 for the UI specifications.

**Table 2. Universal Input Circuit Specifications.**

Input Type	Sensor Type	Operating Range
Room/Zone Discharge Air Outdoor Air Temperature	20K Ohm NTC	-40° F to 199° F (-40° C to 93° C)
Outdoor Air Temperature	C7031G <sup>a</sup>	-40° to 120°F (-40° to 49°C)
	C7041F <sup>a</sup>	-40° to 250°F (-40° to 121°C)
	PT1000 (IEC751 3850)	-40° F to 199° F (-40° C to 93° C)
TR23 Setpoint Potentiometer	500 Ohm to 10,500 Ohm	-4° DDC to 4° DDC (-8° DDF to 7° DDF) or 50° F to 90° F (10° C to 32° C)
Resistive Input	Generic	100 Ohms to 100K Ohms
Voltage Input	Transducer, Controller	0 - 10 Vdc
Discrete Input	Dry Contact closure	OpenCircuit ≥ 3000Ohms ClosedCircuit < 3000Ohms

<sup>a</sup> C7031G and C7041F are recommended for use with these controllers, due to improved resolution and accuracy when compared to the PT1000.

## CPU

Each device uses a 32 bit ATMEL ARM 7 microprocessor.

## Memory Capacity

**Flash Memory:** 512 kilobytes. The device is able to retain Flash memory settings for up to ten (10) years.

**RAM:** 128 kilobytes

## Device Status LED

The LED on the front of the device provides a visual indication of the status of the device. When the device receives power, the LED appears in one of the following allowable states, as described in Table 3.

**Table 3. Status LED States.**

LED State	Blink Rate	Status or Condition
OFF	not applicable	No power to processor, LED damaged, low voltage to board, first second of power up, or loader damaged.
ON	ON steady; not blinking	Processor not operating. Application Program CRC being checked. This takes 1-2 seconds and occurs on each restart (power up, reset and reflash, and following configuration file download).
Very Slow Blink (continuous)	1 second ON, 1 second OFF	Device is operating normally.
Slow Blink (continuous)	0.5 second ON, 0.5 second OFF	Device alarm is active or device in process of configuration file download.

## Sylk™ Bus

Sylk is a two wire, polarity insensitive bus that provides both 18 VDC power and communications between a Sylk-enabled sensor and a Sylk-enabled controller. Using Sylk-enabled sensors saves I/O on the controller and is faster and cheaper to install since only two wires are needed and the bus is polarity insensitive. Sylk sensors are configured using the latest release of the Spyder Tool for WEBPro and WEBStation.

## Mounting

The Sylk IO device enclosure is constructed of a plastic base plate and a plastic factory-snap-on cover. The cover does not need to be removed from the base plate for either mounting or wiring. Removable terminal blocks are used for all wiring connections, which allow the device to be wired before or after mounting.

The Sylk IO device can be mounted in any orientation. Ventilation openings are designed into the cover to allow proper heat dissipation, regardless of the mounting orientation.

The device mounts to either a panel or a DIN rail [standard EN50022; 1-3/8 in. x 9/32 in. (7.5 mm x 35 mm)].

- For panel mounting, use four No. 6 or No. 8 machine sheet metal screws inserted through the corners of the base plate.
- For DIN rail mounting, refer to the Installation Instructions, form 62-0310.

**NOTE:** The Sylk IO device must be mounted in a position that allows clearance for wiring, servicing, and removal.

**NOTE:** For complete mounting information, refer to the Installation Instructions, form 62-0310.

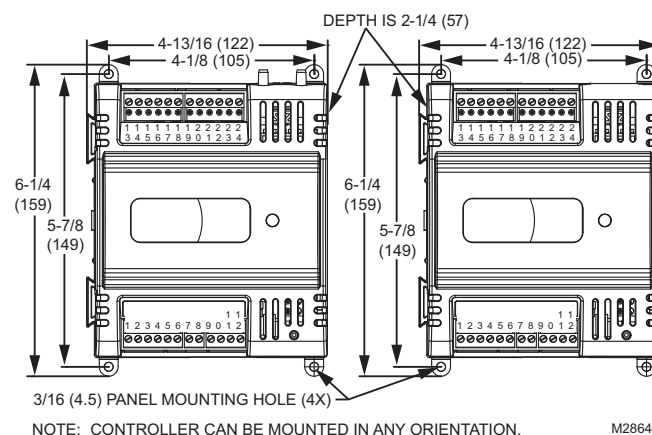

**Fig. 1. Device dimensions in in. (mm).**

By using this Honeywell literature, you agree that Honeywell will have no liability for any damages arising out of your use or modification to, the literature. You will defend and indemnify Honeywell, its affiliates and subsidiaries, from and against any liability, cost, or damages, including attorneys' fees, arising out of, or resulting from, any modification to the literature by you.

Niagara Framework® and the Niagara Framework® logo are registered trademarks of Tridium, Inc.

**Automation and Control Solutions**

Honeywell International Inc.  
1985 Douglas Drive North  
Golden Valley, MN 55422  
customer.honeywell.com

© U.S. Registered Trademark  
© 2014 Honeywell International Inc.  
31-00013—03 M.S. Rev. 08-14  
Printed in United States

**Honeywell**