

HEIPTZ-2201W-IR

www.asia.security.honeywell.com

1080P HIGH DEFINITION IP EXPLOSION-PROOF PTZ CAMERA WITH IR ILLUMINATOR

Honeywell HEIPTZ-2201W-IR is an IP explosion-proof PTZ camera featuring superior 1080P high definition image quality, Wide Dynamic Range (WDR), True Day/Night (TDN), a built-in IR illuminator, and ATEX certified construction. This advanced IP camera is designed for installation in potentially explosive atmospheres, such as petrochemical fields, oil refineries, LNG facilities and so forth.

The HEIPTZ-2201W-IR delivers high definition images of 1080P (1920 x 1080) resolution at up to 30 frames per second. Its 360° continuous rotation and 20x zoom lens deliver a full picture of the area under surveillance in optimal width and depth.

With 80-meter IR distance, the IR illuminator of the HEIPTZ-2201W-IR is assembled for providing clear images for surveillance in dim environments and at complete darkness. Also featuring WDR and TDN, the HEIPTZ-2201W-IR is capable to adapt to various lighting conditions which guarantees superior image quality any time.

By applying the H.264 video compression technology, the HEIPTZ-2201W-IR streams high quality images at optimized bandwidth which reduce data volume effectively to save storage space.

The 304 stainless steel construction is complied with international explosion protected equipment standards ATEX. It also meets IP68 waterproof standard to make the HEIPTZ-2201W-IR an ideal camera for even the most hazardous locations. Also equipped with a built-in heater to prevent condensation and a wiper for cleaning the viewing glass, this IP explosion-proof camera ensures clear and detailed images to be captured at all time.

Marker Opportunities

With a rigid stainless steel ATEX certified construction, the HEIPTZ-2201W-IR explosion-proof PTZ camera delivers a high-definition 1080P video surveillance solution for security applications used in potentially explosive atmospheres. Also featuring 20x zoom, True Day/Night, Wide Dynamic Range, H.264 compression and ONVIF standard, the HEIPTZ-2201W-IR provides optimum surveillance performance in oil refineries, chemical plants, coal mines, marine applications and so on.



Driving IP-based physical security through global standardization

HEIPTZ-2201W-IR

www.asia.security.honeywell.com

1080P HIGH DEFINITION IP EXPLOSION-PROOF PTZ CAMERA WITH IR ILLUMINATOR

FEATURES

- Stainless steel 304 construction
- ATEX II 2 GD; Exd IIC T6 Gb, Ex t IIIC T80°C Db
- Waterproof IP68 rating
- 1080P resolution at up to 30 fps
- 0.01°~30° per second variable speed in horizontal and vertical
- 360° continuous pan rotation
- -90° to +90° tilt range
- ±0.1° positioning accuracy in horizontal and vertical
- 20x optical zoom
- 80m reachable infrared illuminator
- True Day/Night with IR-cut filter; Wide Dynamic Range
- Multiple H.264 streams and MJPEG streams ensure simultaneous real-time monitoring and high resolution recording
- H.264 main profile helps save network bandwidth and storage resources
- Built-in wiper on the lens cover to remove condensed water
- Built-in heater to prevent condensation
- IP platform: Honeywell Universal Surveillance (HUS)
- ONVIF compliance

SPECIFICATIONS

PTZ System	
Pan Angle	0 - 360° continuous rotation
Tilt Angle	-90° ~ 90°
Pan Speed	0.01° to 30°/sec variable-speed operation
Tilt Speed	0.01° to 30°/sec variable-speed operation
Zoom	20x optical zoom
Scan Speed	Configurable between 0.01° and 30° /sec
PTZ Tours (Pattern)	2 patterns
Preset Speed	30°/sec
Preset Positions	128
Illuminator	Infrared, 80m reachable
Video	
Image Sensor	1/2.8" Progressive Scan CMOS
Effective Pixels	1920 (H) x 1080 (V)
Min. Illumination	0.1 Lux (Color); 0.005 Lux (B/W); 0 Lux (B/W, IR on)
Day/Night	TDN
S/N Ratio	≥50dB
Shutter Speed	1 – 1/30000 sec
Focal Length	f=4.7 - 94mm
Aperture Range	F1.6 – F3.5
Wide Dynamic Range	ON/OFF
Digital Noise Reduction	ON/OFF

HEIPTZ-2201W-IR

www.asia.security.honeywell.com

1080P HIGH DEFINITION IP EXPLOSION-PROOF
PTZ CAMERA WITH IR ILLUMINATOR

SPECIFICATIONS

Video	
Video Output	YUV422 (Y8bit + C8bit); TU-R BT, 709; TU-R BT, 1120 compliance
Video Standard	PAL, NTSC
Privacy Masking	4 mask zones (configurable in size)
Automatic Lens Control	Auto focus, Auto Iris
Gain Control	Automatic/OFF
Angular Field of View	55.2°(w) - 2.9°(t)
White Balance	Auto/Manual
IP Specification	
Video Compression	H.264 / MJPEG
Image Resolution	"Main stream 1920 x 1080 @ 25/30fps Extra stream 640 x 480, 320 x 240, 160 x 112 @ 25/30fps"
Bit Rate	32kbps – 16Mbps continuously adjustment; CBR/VBR
Supported Protocol	TCP/IP, UDP, RTP, RTSP, RTCP, HTTP, DNS, DDNS, DHCP, FTP, NTP, PPPOE, SMTP, UPNP
Security	Password protection, IP address filtering, User access log
User	2 simultaneous users
Communication Protocol	ONVIF
Alarm	
Alarm Trigger	Intelligent video motion detection and external input
Alarm Event	Event server: FTP server, SMTP server, Web browser
Electrical	
Power Supply	24V AC, ±25%
Power Consumption	100W max
Electrical Connections	1m pigtail wire harness with connections for power, network and earth
Mechanical	
Dimensions	300(W) x 366(H) x 498(L) mm
Weight	31kg
Viewing Window	Double-sided Nano filming tempered glass
Construction	Stainless steel 304
Mounting	Upright mount
Cable Entry	One M25 ISO metric screw thread opening; one explosion proof sealable fitting supplied
Environmental	
Operating Temperature	-40°C to +60°C
Protection Class	IP68 waterproof
Viewing System	
Browser	IE 6.0 or above
Media Player	VLC, Quick Time, Real Player
Software	
Operating Platform	Honeywell HUS Platform 4.1 or above
Regulatory	
Certification	ATEX II 2 GD; Exd IIC T6 Gb, Ex t IIIC T80°C Db

HEIPTZ-2201W-IR

www.asia.security.honeywell.com

1080P HIGH DEFINITION IP EXPLOSION-PROOF
PTZ CAMERA WITH IR ILLUMINATOR

DIMENSIONS

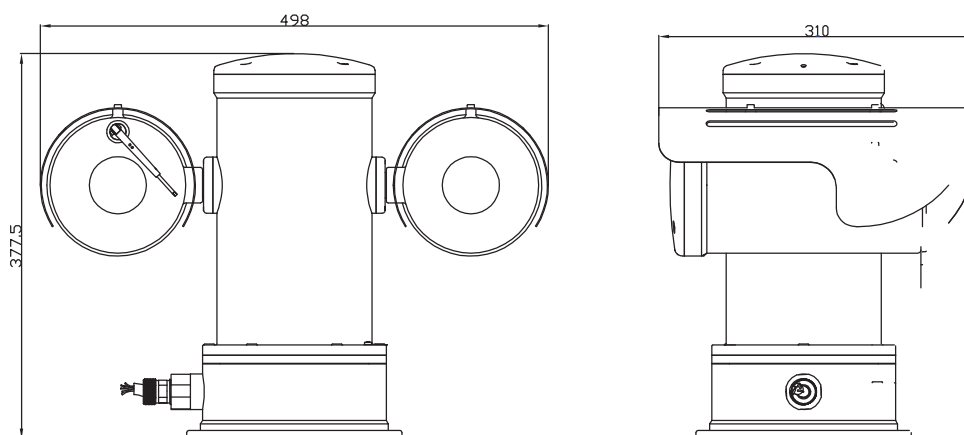

ORDERING

HEIPTZ-2201W-IR	1080P Explosion-proof PTZ Camera, IR Illuminator, IP68, TDN, WDR, ONVIF
-----------------	---

For more information:

Security Asia Pacific Headquarters
Security Australia
Security China
Security Hong Kong
Security India

Tel: (86) 21 2219 6888
Tel: (61) 2 8837 9333
Tel: (86) 21 2219 6888
Tel: (852) 2405 2323
Tel: (91) 124 497 5000

Security Indonesia Tel: (62 21) 536 52322
Security Korea Tel: (82) 2 799 6114
Security Singapore Tel: (65) 6355 2828
Security Taiwan Tel: (886) 2 2245 1000
Security Thailand Tel: (66) 2 693 3099

www.asia.security.honeywell.com
security.ap@honeywell.com

Honeywell Security & Data Collection
Automation & Control Solutions
Honeywell International Inc.
www.security.honeywell.com

Apr 2013
© 2013 Honeywell International Inc.

Honeywell