

# 1080P AHD IR Fixed Lens Cameras

HEL2R1 CCTV Camera (Dome)  
HBL2R1 CCTV Camera (Bullet)



## About Honeywell Performance AHD

The Honeywell Performance AHD series is designed for small-to-medium scale surveillance applications at a very cost-effective price.

Honeywell's latest product offering includes four types of 1080P HD Analog IR Fixed/Vari-focus eyeball and bullet cameras, and three types of 4/8/16 channel DVR with the no latency 1080P live view.

Featuring advanced Analog High Definition (AHD) video technology, the Performance AHD series HBL2R1 and HEL2R1 are HD analog cameras which provide 1080P (1920X1280) sharp, high definition images. The AHD technology ensures real-time and non compressed signal transmission via coaxial cable, which significantly reduces installation cost and provides much sharper images without video quality loss.

## Market opportunities

- The HEL2R1/HBL2R1 cameras are cost effective surveillance solutions suitable for various applications, including schools, colleges, hotels, hospitals, commercial sites, retail stores, warehouses, banks among others.
- Features 3.6mm built-in lens, 1080P resolution, TDN function and IR night vision.
- Ideal for easy and cost-effective upgrade of existing analog systems to high definition surveillance.

## FEATURES

---

- 1080p real time live view
- 1/2.7" CMOS progressive scan
- Minimum illumination: 0 Lux (IR on)
- TDN (IR-Cut), AGC, DWDR
- 3.6mm Lens
- IR distance: Upto 20 meters
- Power:12VDC
- Output: AHD/CVBS

# HEL2R1 and HBL2R1 Product Specifications

MODEL	HEL2R1	HBL2R1
<b>SYSTEM</b>		
VIDEO STANDARD	PAL/NTSC	
SCANNING SYSTEM	Progressive	
IMAGE SENSOR	1/2.7" 2Megapixel CMOS	
RESOLUTION	1080P	
NUMBER OF PIXELS	1928(H) x 1088(V)	
MINIMUM ILLUMINATION	0.01lux@F1.2, 0 Lux IR on	
VIDEO OUTPUT	AHD, CVBS	
VIDEO FRAME RATE	25 / 30 fps	
SYNC SYSTEM	Internal	
AUTOMATIC ELECTRONIC SHUTTER	1/25 ~ 1/50000	
<b>LENS</b>		
FOCAL LENGTH	3.6 mm	
ANGLE OF VIEW	H: 80.6°	
LENS TYPE	Fixed	
<b>CAMERA FEATURES</b>		
IR LED'S	18 PCS	
IR ILLUMINATION DISTANCE	20m	
SNR	More than 50dB	
DAY/NIGHT	Auto	
AUTOMATIC GAIN CONTROL	Auto	
WHITE BALANCE	Auto	
DIGITAL NOISE REDUCTION	3DNR	
WDR	DWDR	
OSD	Yes	
<b>ELECTRICAL</b>		
INPUT VOLTAGE	DC12V±10%, 500mA	
POWER CONSUMPTION	Max 6W	
<b>MECHANICAL</b>		
DIMENSIONS	∅94.5 x 76(H) mm	151(W) x 73(H) x 73(D)mm
WEIGHT	0.3 Kg	0.3 Kg
CONSTRUCTION	METAL	
<b>ENVIRONMENTAL</b>		
OPERATING TEMPERATURE	-10°C to +50°C	
RELATIVE HUMIDITY	10% to 95%, non-condensing	
IP RATING	IP 66	
<b>REGULATORY</b>		
CERTIFICATION	CE, FCC	
<b>SYSTEM COMPATIBILITY</b>		
COMPATIBLE DVR	HRLT1040 / 1080 / 1160	

## Box Includes

NAME	HEL2R2	HBL2R2
CAMERA	1	1
USER GUIDE	1	1

Note: Honeywell reserves the right, without notification, to make changes in product design and/or specifications.

# HEL2R1 and HBL2R1 Dimensions

## HEL2R1

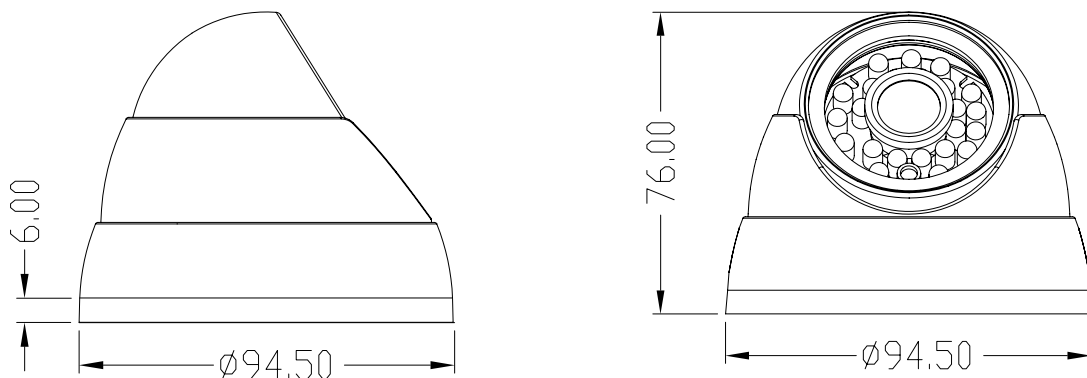

## HBL2R1

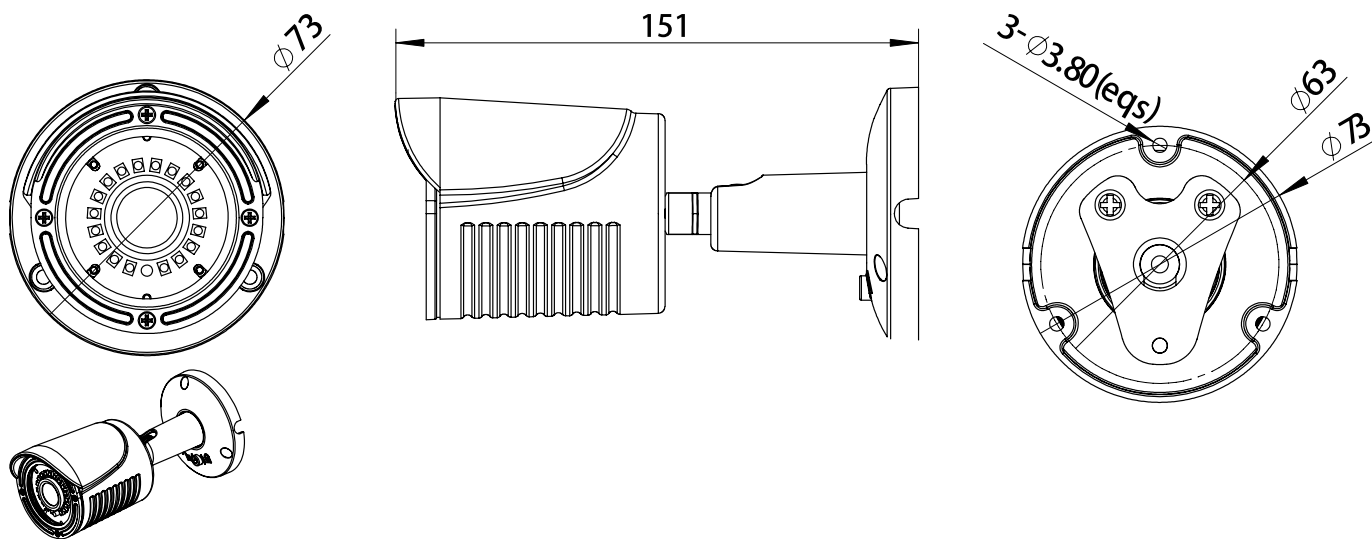

### ORDERING INFORMATION

HEL2R1	1/2.7" CMOS sensor, 1080p AHD, TDN, DNR, DWDR, 18 LED, 3.6mm, IR Dome Camera, 12VDC with OSD, PAL/NTSC
HBL2R1	1/2.7" CMOS sensor, 1080p AHD, TDN, DNR, DWDR, 18 LED, 3.6mm, IR Bullet Camera, 12VDC with OSD, PAL/NTSC

**For more information, please contact :**

Nikhil gupta (Product Marketing Manager - Video)

Email: Nikhil.Gupta3@honeywell.com

**APAC AND ASEAN HQ Honeywell Security and Fire**

Honeywell Engineering Sdn Bhd

1st Floor, Block B

No. 10, Jalan Bersatu 13/4

46200 Petaling Jaya

Tel: +603 7626 5700

**INDIA HQ Honeywell Security and Fire**

Honeywell Security & Fire

Unitech Trade Center, 1st Fl, Sector-43, Block-C

Gurgaon 122002 Haryana, India

Tel: +91 124 6715000

**KOREA HQ Honeywell Security and Fire**

Honeywell Co Ltd (Korea)

Sangam-dong, Sangam IT Tower 5F

434, Worldcupbuk-ro, Mapo-gu, Seoul,

03922 Korea

Tel: +82 2 799 6114

**Honeywell Security & Fire (Pacific)**

Honeywell Ltd

Unit 5, 24-28 River Rd West

Parramatta

NSW 2250

Tel: +1300 234 234

**Honeywell Security & Fire (Pacific)**

Honeywell Ltd

9 Columbia Way

Norwest Business Park

BAULKHAM HILLS NSW 2153

Tel: (02) 9899 4155

Honeywell reserves the right, without notification, to make changes in product design or specifications.

HEL2R2, HBL2R2 | 10/16 | Rev 1  
© 2016 Honeywell International Inc.

**Honeywell**